

# Grid 13

Manual & Safety

# Smartbox

Communication is life

This device is manufactured by Smartbox Assistive Technology Ltd.

## United Kingdom

Smartbox Assistive Technology Ltd  
Ysobel House, Enigma Commercial Centre  
Sandys Road  
Malvern  
WR14 1JJ

## United States

Smartbox Inc.  
167 Hillcrest Shopping Center  
Lower Burrell  
PA, 15068

## Europe

REHAVISTA GmbH  
Konsul-Smidt-Str. 8c  
28217 Bremen  
Germany

Document:	Grid Pad 13 - Manual & Safety - UK - B
Device:	GP13A
Language:	English
Date of issue:	February 2024

Copyright © 2024 Smartbox Assistive Technology

---

# Grid Pad 13

## Manual

This guide provides the basics for getting started with your Grid Pad 13.

You can find a complete guide to all the features for Grid Pad 13 on the Smartbox Hub. A large print version is also available online.



[hub.thinksmartbox.com/topic/grid-pad-13](http://hub.thinksmartbox.com/topic/grid-pad-13)

# Your Grid Pad

## Front

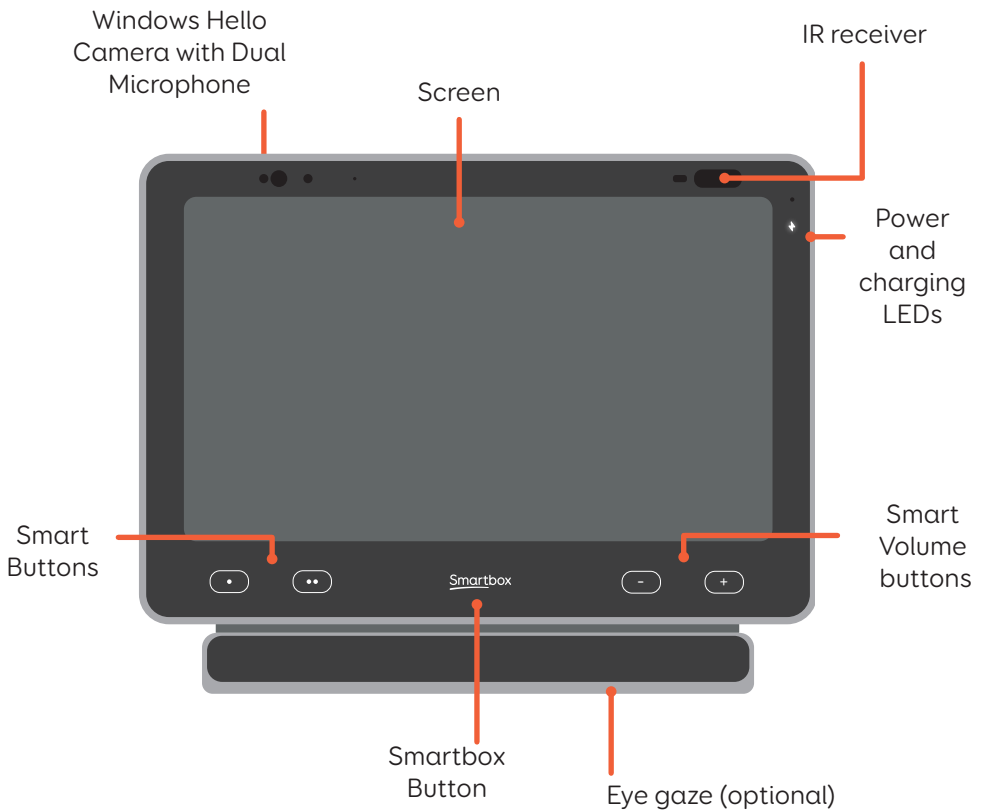

## Top

IR transmitter

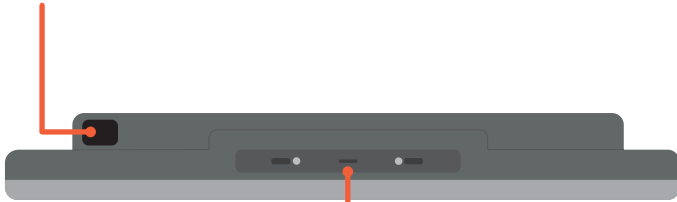

USB-C 2.0  
(Under magnetic cover)

## Left



USB-C 4.0

USB-A 3.1

Charging port

Personal speakers

Eye gaze (optional)

Stand

## Right



Switch ports

USB-A 3.1  
(under cover)

Kensington Nano lock

Personal speakers

Eye gaze (optional)

Stand

## Back

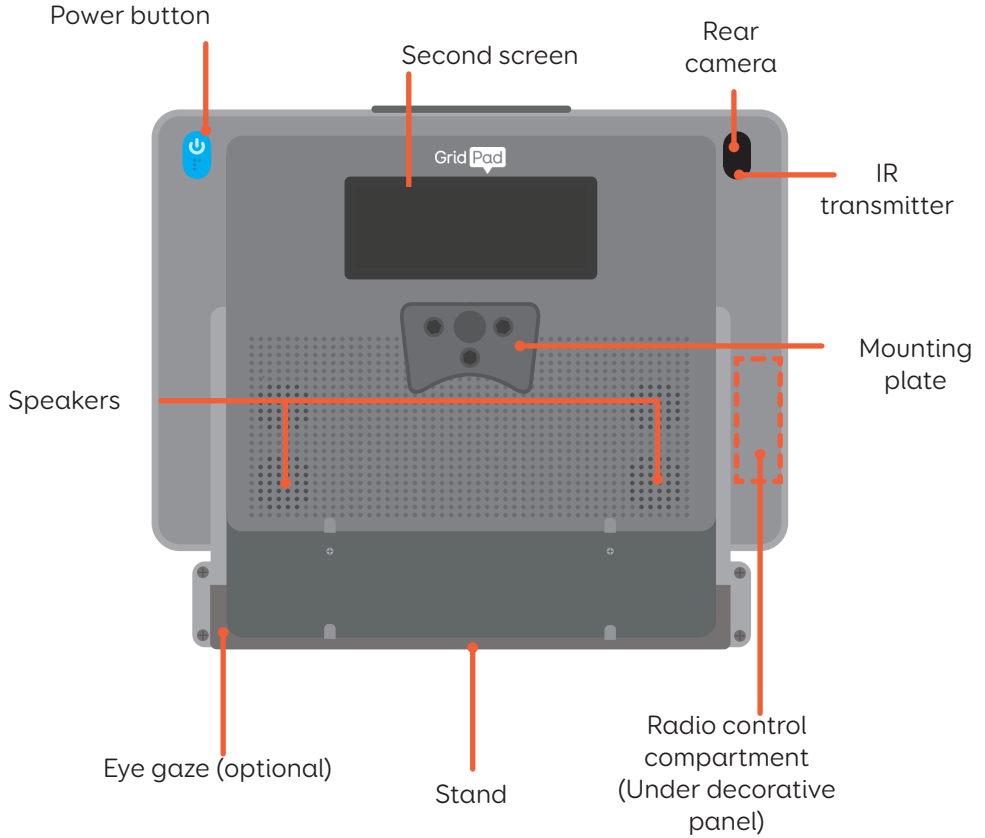

## Eye gaze dock on bottom of Grid Pad

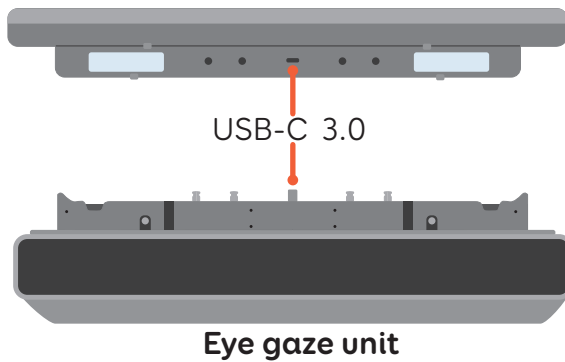



**Read more about the specification of Grid Pad 13**



**Learn more about the materials used in Grid Pad 13 and its packaging:**



**Visit the Smartbox Hub for a large print version of the Grid Pad 13 manual**



## Whats in the box?

- Grid Pad 13
- Remote power button
- Manual
- Power Supply (PSU)
- Cleaning cloth
- 2x AAA batteries (in the Remote power button)
- Port labels

Your Grid Pad may also be supplied with an eye gaze unit



Your Grid Pad has many features that can be customised and controlled in Grid.

**For more resources and guides on how to get started with Grid visit the Smartbox Hub.**

- Get started with Grid
- Access methods and setup
- Troubleshooting guides
- Videos and webinars
- Resources for grid sets
- ...and much more

# Power

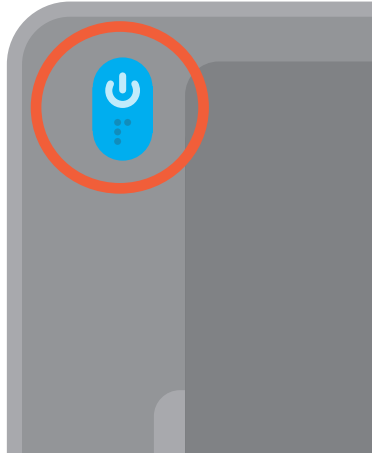

To power on your Grid Pad press the power button on the back of the device. A white light on the front of the device will come on and the system will start up.

If the device is in sleep mode it will wake up.

## Shutting down your Grid Pad

1. Tap the Start menu
2. Select the Power icon
3. Select Shut down

You can also Restart your device from here, which will apply any updates.

## Force shut down

If you press and hold the power button for five seconds, your Grid Pad will shut down. Please note that this is only recommended in emergencies.

## Charging

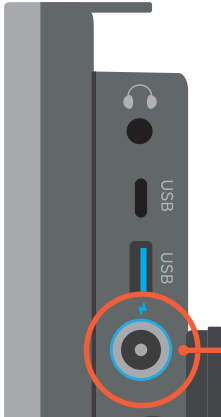

To charge your Grid Pad, plug the Power Supply Unit (PSU) into the charging port on the side of the device. When the Grid Pad is charging the charging indicator is **illuminated white**.

Power cable socket

## Attaching PSU

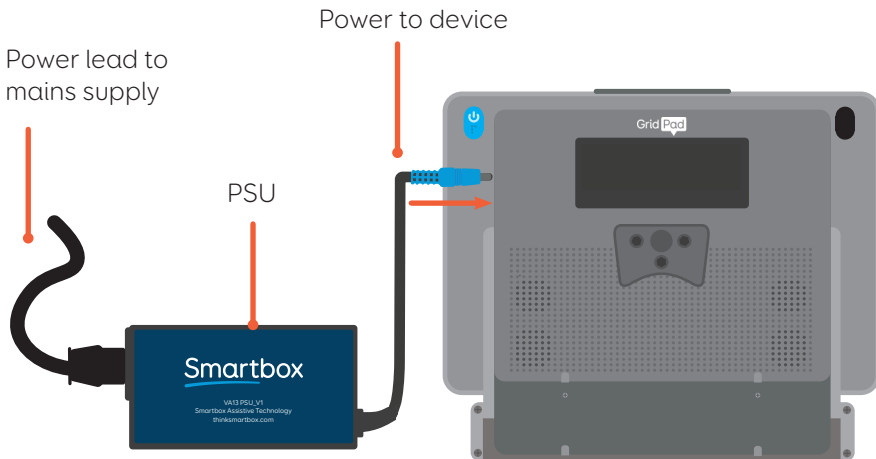

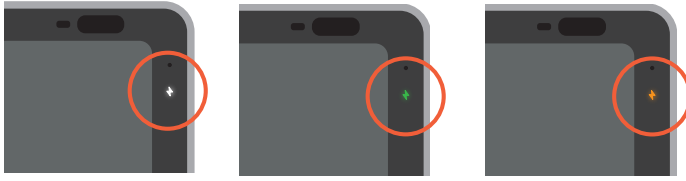

When the battery is full the charging indicator is illuminated **green**. When your Grid Pad requires charging, the charging indicator will be illuminated **orange**.

## Mounting

### Adjustable stand

To use the stand, pull from the bottom and adjust the angle to suit you. When finished, simply push the stand back in.



### Using a desk, floor, or wheelchair mount

Your Grid Pad is supplied with a Rehadapt / Daessy mount.

The mounting plate is attached with three screws (supplied with the mounting plate). Ensure all three screws are secure before mounting your Grid Pad to a stand or mounting system.

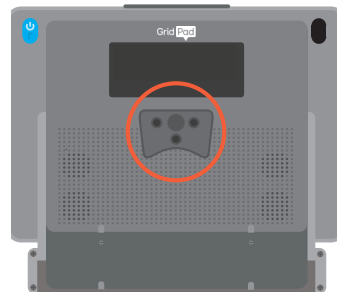

## Smart Buttons

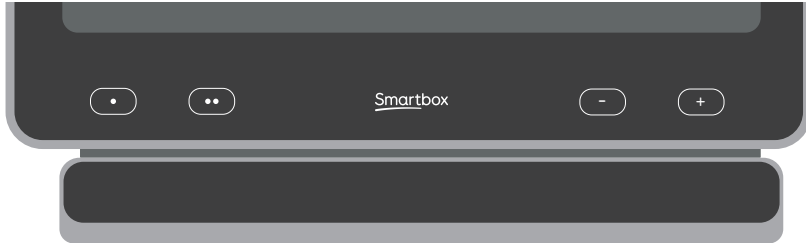

The front of your Grid Pad has five Smart Buttons that are accessible with eye gaze and touch.

Buttons 1, 2 and the Smartbox button can help you control and navigate your Grid Pad device when using Grid, or they can be customised using Grid's set of powerful commands. You can customise the colour of the smart button highlight as well as add audio feedback.

The two Smart volume buttons cannot be customised and offer eye gaze access when using Grid.

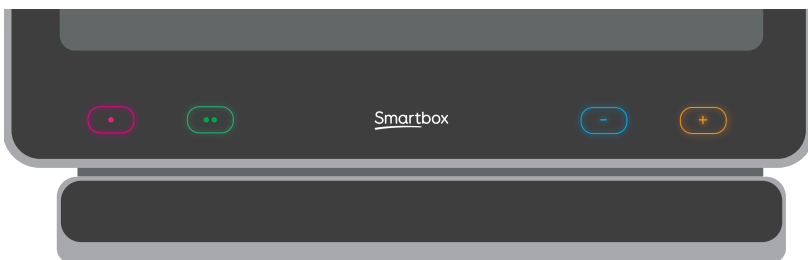

## Connecting switches

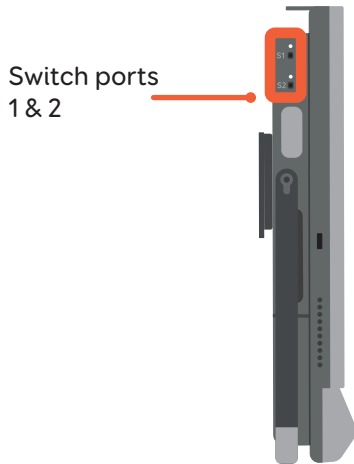

Your Grid Pad has two switch ports which can be configured in Grid.

Switch ports S1 and S2 have an LED indicator above that illuminate when a switch is activated.

The Remote Power Button also has two additional switch ports, S3 and S4.

## Remote power button

Your Grid Pad has a Remote Power Button included.

The Remote Power Button allows you to turn your Grid Pad on and off.

It can also be used to setup switches away from the device.

The switch port S3 also acts as a power button. This can be toggled in your Grid settings.

The Remote Power Button comes paired with your Grid Pad out of the box.



## Second screen

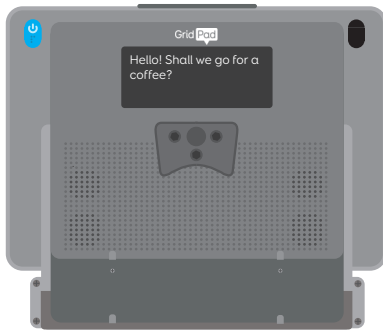

The second screen on the back of the Grid Pad can show your Grid messages and Symoji's to the people around you.

The second screen can be toggled on and off in the Grid settings, and using the Set Second Screen command in your grid sets.

## Finding your model and serial number

When you contact our Support team, please have your device model and serial number to hand.

The serial number for the device is placed under the stand, lift the stand and the serial number is found here:



# Cleaning, decontaminating and storing

## Cleaning and decontaminating your device

- Before cleaning shut down your device and unplug the PSU
- Remove any cables that are connected to the device
- Using a damp cloth or alcohol wipe, clean all the external surfaces
- Allow the device to dry
- Repeat the process for any accessories you may use with the device
- Once dry, the screen can also be cleaned using a microfibre cloth
- Tough dirt and residue can be removed using a toothbrush or similar.

Do not use spray cleaning fluid, gel, or polish directly onto your Grid Pad, or immerse the device in water.

## Storing your Grid Pad

When not in use, your Grid Pad should be stored safely.

Do not rest or press hard objects against the screen. Disconnect any devices plugged into the ports of the Grid Pad, including USB ports, switch ports and the power lead.

## Storing the remote power button

When packing away your Grid Pad, we recommend removing the AAA batteries from the remote power button and disconnecting any switches.

## Technical specification

Model number: GP13A

### Operating environment

Temperature	0 - 35°C
Relative humidity	0 - 90%
Atmospheric pressure	70kPa to 106kPa



### Storage and transport environment















Temperature:	-20°C - 60°C
Relative humidity:	5 - 90%
Atmospheric pressure:	50kPa to 106kPa

### Safety classification

Protection against electrical shock	Class I and internally powered
Mode of operation	Continuous

## Symbol explanation

Symbol	Meaning
	Headphone port
	Charging port and indicator
S1	Switch port 1
S2	Switch port 2

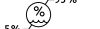
S3	Switch port 3
S4	Switch port 4
	Conformity European symbol to declare conformity with EU legislation
	Federal communications commission symbol to declare conformity with US legislation
	Waste electrical and electronic equipment symbol to indicate you should dispose of this equipment in accordance with local regulations
	Power button symbol
+	Increase volume symbol
-	Decrease volume symbol
	Read the manual symbol
	Read the manual symbol
IP54	Ingress protection rating 54
	UK Conformity Assessed symbol to declare conformity in the UK
	Unique device identifier
	Medical device
	EU Authorised Representative
	Swiss Authorised Representative
	Model number
	Serial number
	Min / Max storage and transport temperature
	Min / Max storage and transport humidity

## Intended use, user and environment

### Model number: GP13A

Grid Pad 13 has been tested as a Class 1 medical device. Specifications and standards have been listed in the Compliance section of this manual.

Please consider these safety warnings to ensure safe operation of your Grid Pad.

### Application

#### Intended Use

- It is used as a voice out put communication aid (VOCA)
- It is used to control Windows computer

- It is used to operate external devices via environmental control (EC)

#### Intended User

It is designed for individuals with complex communication and/ or access needs. Complex communication and/or access needs may arise as a result of a variety of conditions including but not limited to:

- Developmental disorders, e.g. cerebral palsy, developmental verbal dyspraxia, autistic spectrum disorder (ASD), developmental language disorder (DLD), global delay.
- Acquired disorders, e.g. cardiovascular accident (CVA / stroke), dementia, traumatic/ acquired brain injury (TBI/ ABI)

It may also be used by individuals with complex access needs in the absence of communication difficulties for computer control, environmental control and non-face-to-face communication e.g. including but not limited to individuals with:

- Spinal cord injury
- Degenerative neuromuscular disease (e.g. muscular dystrophy, spinal muscular atrophy)

### **Intended environment**

It can be used in a variety of settings in which the individual is likely to wish to utilise it for the above intended use. These settings may include but are not limited to:

- supported living homes
- nursing care facilities
- schools, colleges, universities
- in the community, e.g. shops, restaurants
- hospitals (acute, rehabilitation and community)

### **Significant contra-indications, warnings and precautions**

Although designed to assist with expressive communication, it should be used in combination with a range of augmentative and alternative communication (AAC) methods and therefore should not be relied on in isolation to enable an individual to communicate expressively.

Other methods of AAC may include the use of paper-based systems, sign language or the use of eye pointing frames. Despite this, it is recognised that individuals with signification communication and/or access difficulties will rely heavily on a VOCA (in this instance Grid Pad) to communicate given the significant enhancement to expressive communication that a VOCA often brings.

Although designed and manufactured to be extremely robust and reliable, it is possible to lose function due to power loss or other technical issues. For this reason, it should not;

- be used as a life supporting device
- be relied upon for well-being
- be relied upon as the user's only way of making an emergency call or alarm
- be used to administer medicine.
- be relied upon as the only method of interaction with EC devices.

It is also not intended to provide information which is used to take decisions with diagnosis or therapeutic purposes.

When the device is working with other equipment, there may be interference. For this reason, Grid Pad should not be used:

- in an MRI environment.
- in an X-ray environment
- in a military environment
- in a harsh RF environment

### **Accessories**

Grid Pad 13 is compatible with a number of accessories that can be combined together to adjust its function as a VOCA.

For information on compatible accessories that are currently available visit:

[hub.thinksmartbox.com/topic/grid-pad-13](http://hub.thinksmartbox.com/topic/grid-pad-13)

### **Avoiding hearing damage**

Using headphones and speakers at high volume can cause permanent hearing loss. Always keep the volume of your device at a safe level.

### **Durability**

Your Grid Pad is tough and rugged but must be handled with care when moving around. It has been drop tested to one metre. Please note this does not include accessories.

### **Water and liquids**

Your device is protected from splashing water and light rain. Do not get water or liquids on the back of the device, especially in the ports or vents.

Do not submerge the device in water. When the port covers are removed, the USB ports are not protected.

## Contact with user

BF of applied part	BF
Applied part	Screen, enclosure

The screen and enclosure can reach 43°C. This feels warm, but is safe for contact with the user. There is no time limit for contact at 43°C, but please cease contact if you feel any discomfort.

If the device reaches 43°C it will automatically reduce performance to keep temperature below 43°C.

Touching the surface of the device with broken skin may aggravate a wound.

Infants or high-risk groups should not touch the surface of the device if there is a chance of burning the skin.

Do not leave the device on the users lap or body if they cannot remove it.

If used in hot temperatures or direct sunlight, your Grid Pad may reach temperatures that can trigger an automatic shut-down. This is a safety feature to prevent lasting damage to the device. If this occurs, please wait until your device has cooled before restarting.

### Mounting

When mounting your Grid Pad, follow the instructions in both your Grid Pad and your mounting system manufacturer's guide. While we have taken every precaution to make this an easy and safe process, it is up to you to ensure the device is mounted safely.

Please use the dual DAESSY and Rehadapt mounting solution provided. Ensure the mounting system you select is correct for your needs and perform a risk analysis if required.

### Ports & Connections

Accessories connected to ports for a SIGNAL INPUT/OUTPUT must be compliant to the IEC standard 60601-1 or 609501/62368-1.

### Choking hazard

If damaged, small parts may detach from your Grid Pad. These can present a choking hazard. Young children and people with cognitive disabilities should be supervised when using the device. They should also be supervised when unpacking the device as packaging can present a choking hazard.

### Not sterile

Grid Pad is not sterile. Do not operate with open wounds, or whilst undergoing invasive medical treatments.

### Strangulation hazard

Grid Pad is supplied with a power cable and can be used with cabled accessories. These can present a strangulation hazard.

### Epilepsy warning

Some people with photosensitive epilepsy are susceptible to seizures when exposed to certain lights or light patterns. If you feel odd or nauseous when in front of your Grid Pad, particularly if you are using it with an eye gaze camera, move away from the device and consult a medical professional.

### Warranty

Your Grid Pad is covered under the standard 2 year warranty from the time of purchase.

## Repairs and Maintenance

Your Grid Pad is not a user serviceable device. If your device requires a repair, please contact your local dealer.

Smartbox will provide information such as circuit diagrams and component lists to maintenance personnel when necessary.

## Troubleshooting and Customer Support

Contact support at: [hub.thinksmartbox.com](http://hub.thinksmartbox.com)

Please have your serial number ready. This can be found under the stand on your device.

## Incidents

If a serious incident occurs in relation to the device, please report to Smartbox ([repairs@thinksmartbox.com](mailto:repairs@thinksmartbox.com)) and the competent authority of your member state.

## Disposal

Please dispose of in line with local electronic waste regulations.

# Safety warnings

## Power supply and batteries

Your Grid Pad contains a rechargeable lithium ion battery. All rechargeable batteries degrade over time. The usage time for a Grid Pad after a full charge can become shorter over time.

For optimal performance your Grid Pad should not be charged at extreme temperatures of below 0°C or above 45°C. At these temperatures your battery will charge slowly or not at all.

Do not expose your Grid Pad to fire or temperatures above 90°C as these conditions can cause the battery to malfunction, ignite or explode.

Only charge your Grid Pad with the supplied power lead. Using unofficial power supplies may cause severe damage to your Grid Pad and cause fire. If your Grid Pad's power lead is lost or damaged, contact your supplier.

When your Grid Pad's battery is depleted, and the device is not connected to a power source, the device will automatically shut down to avoid damaging the battery and hardware.

## Refurbishment

If the device is in need of repairs before it is re-used, please contact your local dealer. Before reuse of the device, ensure the cleaning and decontamination procedure has been carried out. You may also need to remove any personal data from the device. For support and advice, please contact Smartbox.

## Data security

The device incorporates electronic programmable systems and software. For the best performance we recommend keeping the operating system and supplied software updated with the latest security fixes and features.

Ensure that passwords and pass codes are kept securely to prevent unauthorised access.

The device has features that require an internet connection. Access to these services can be restricted as part of the setup of the device or through network administration.

The operating system will attempt to do this as safely as possible, however it is recommended to connect the power lead before your Grid Pad shuts down.

The battery that powers your Grid Pad is subject to shipping regulations. Check with your postal service or courier before shipping to ensure safe delivery of your device. Do not place your device in a place where the power adapter plug is difficult to disconnect from the socket.

To avoid personal injury or equipment damage, only our authorised personnel are permitted to replace a Grid Pad battery.

Do not service or perform maintenance on the device while the device is in operation. Make sure to shut the device down and unplug all cables before starting service or maintenance work on the device.

## Transporting your Grid Pad

When in transit, ensure your Grid Pad is sufficiently protected from knocks and bumps.

There are strict regulations for lithium ion batteries on airplanes. Rules vary between airlines, so it is

## Battery warnings

Do not dismantle, open or shred the battery.

Do not expose the batteries to heat or fire, and avoid storage in direct sunlight.

Do not short-circuit the battery.

Do not store the battery haphazardly in a box or drawer where it may be short-circuited by other metal objects.

Do not subject the battery to mechanical shock.

In the event of a battery leaking, do not allow the liquid to come in to contact with the skin or eyes. If contact has been made, wash the affected area with copious amounts of water and seek medical advice.

The PSU is an important part of the equipment, do not use any PSU other than that specifically (Model: VA13 PSU) provided for use with the equipment, and refer to the manufacturer's instructions or



## Statement of compliance

**Requirements in UK 5150MHz-5350MHz is for indoor use only.**

SAR is measured with the device at 0 mm to the body, while transmitting at the highest certified output power level in all frequency bands of the device. The maximum SAR value is 0.324W/kg (body) averaged over 10 gram of tissue. This equipment should be installed and operated with a minimum distance of 0 cm between the radiator and your body.

### EU / CE Statement

Hereby, Smartbox Assistive Technology Ltd. declares that this radio equipment complies with Directive 2014/53/EU. The frequencies used by the wireless networking feature of this product are the 2.4 GHz range.

The full text of the EU declaration of conformity is

recommended to contact your airline before you travel.

### Temperature

Ensure that you shut down your device before storing or placing into a bag.

equipment manual for charging instruction.

Do not use any other battery with the equipment unless approved by Smartbox.

Battery usage by children should be supervised.

Keep the battery clean and dry.

Do not leave a battery on prolonged charge when not in use.

After extended periods of storage, it may be necessary to charge and discharge the battery several times to obtain maximum performance.

Retain the original product literature for future reference.

Only use the battery in the application for which it was intended.

Dispose of the battery according to local regulations.

available here:

[thinksmartbox.com/GP13-DOC](http://thinksmartbox.com/GP13-DOC)

### Applicable Legislation

This equipment complies with the requirements of:

- This equipment complies with the requirements of: EU harmonised legislation (EU) 2017/745 (including EMC Directive 2014/30/EU and LVD Directive 2014/35/EU) RoHS Directive 2011/65/EU WEEE Directives 2012/19/EU

### Harmonised Standards

EN 60601-1:2006/A1:2013

Medical electrical equipment - Part 1: General requirements for basic safety and essential performance

### EN 60601-1-2:2015

Medical electrical equipment - Part 1-2: General requirements for basic safety and essential performance - Collateral Standard: Electromagnetic disturbances - Requirements and tests

### EN ISO 14971:2019

Medical devices - Application of risk management to medical devices

### EN 61000-3-3:2013

Electromagnetic compatibility (EMC) - Part 3-3: Limits - Limitation of voltage changes, voltage fluctuations and flicker in public low-voltage supply systems, for equipment with rated current  $\leq 16$  A per phase and not subject to conditional connection

### EN 50581:2012

Technical documentation for the assessment of electrical and electronic products with respect to the restriction of hazardous substances.

### FCC Statement

FCC ID: **2APMX-GP13A**

Any Changes or modifications not expressly approved by the party responsible for compliance could void the user's authority to operate the equipment.

This device complies with part 15 of the FCC Rules. Operation is subject to the following two conditions:

- (1) This device may not cause harmful interference, and
- (2) this device must accept any interference received, including interference that may cause undesired operation.

### For use in North America

**NOTE:** This equipment has been tested and found to comply with the limits for a Class B digital device, pursuant to part 15 of the FCC Rules. These limits are designed to provide reasonable protection against harmful interference in a residential installation. This equipment generates, uses and can radiate radio frequency energy and, if not installed and used in accordance with the

instructions, may cause harmful interference to radio communications. However, there is no guarantee that interference will not occur in a particular installation. If this equipment does cause harmful interference to radio or television reception, which can be determined by turning the equipment off and on, the user is encouraged to try to correct the interference by one or more of the following measures:

Reorient or relocate the receiving antenna.

Increase the separation between the equipment and receiver.

Connect the equipment into an outlet on a circuit different from that to which the receiver is connected.

Consult the dealer or an experienced radio/TV technician for help.

### RF warning for Portable device:

This equipment complies with FCC radiation exposure limits set forth for an uncontrolled environment. End user must follow the specific operating instructions for satisfying RF exposure compliance. This transmitter must not be co-located or operating in conjunction with any other antenna or transmitter.

The mobile device is designed to meet the requirements for exposure to radio waves established by the Federal Communications Commission (USA). These requirements set a SAR limit of 1.60W/kg averaged over one gram of tissue. The highest SAR value reported under this standard during product certification for use when properly worn on the body is 1.583 W/Kg.

For body operation, this device has been tested and meets FCC RF exposure guidelines when used with any accessory that contains no metal and that positions a minimum of 0mm from the body. Use of other accessories may not ensure compliance with FCC RF exposure guidelines.

### For use in Canada

IC: **24965-GP13A**

Industry Canada Class B Emissions Compliance Statement. This Class B digital apparatus complies with Canadian ICES003.

Under Industry Canada regulations, this radio transmitter may only operate using an antenna of a type and maximum (or lesser) gain approved for the transmitter by Industry Canada. To reduce potential radio interference to other users, the antenna type and its gain should be so chosen that the equivalent isotropically radiated power (e.i.r.p.) is not more than that necessary for successful communication.

This device complies with Industry Canada licence-exempt RSS standard(s). Operation is subject to the following two conditions: (1) this device may not cause interference, and (2) this device must accept any interference, including interference that may cause undesired operation of the device.

Conformément à la réglementation d'Industrie Canada, le présent émetteur radio peut fonctionner avec une antenne d'un type et d'un gain maximal (ou inférieur) approuvé pour l'émetteur par Industrie Canada. Dans le but de réduire les risques de brouillage radioélectrique à l'intention des autres utilisateurs, il faut choisir le type d'antenne et son gain de sorte que la puissance isotrope rayonnée équivalente (p.i.r.e.) ne dépasse pas l'intensité nécessaire à l'établissement d'une communication satisfaisante.

Le présent appareil est conforme aux CNR d'Industrie Canada applicables aux appareils radio exempts de licence. L'exploitation est autorisée aux deux conditions suivantes : (1) l'appareil ne doit pas produire de brouillage, et (2) l'utilisateur de l'appareil doit accepter tout brouillage radioélectrique subi, même si le brouillage est susceptible d'en compromettre le fonctionnement.

The device is designed to meet the requirements for exposure to radio waves established by the Innovation, Science and Economic Development Canada. These requirements set a SAR limit of 1.60W/kg averaged over one gram of tissue. The highest SAR value reported under this standard during product certification for use when properly worn on the body is 1.583 W/kg.

Le dispositif est conçu pour répondre aux exigences de l'exposition aux ondes radio créée par la science et l'innovation, développement économique Canada. Ces exigences limite de sar de 1.60W/kg en moyenne pour un gramme de tissu. La valeur de r - s en vertu de cette norme plus élevée au cours de la certification de produits déclarés pour une utilisation bien portés sur le corps est 1.583 W/kg.



# EMC Declarations

## Guidance and manufacturer's declaration - electromagnetic emission - for all EQUIPMENT AND SYSTEMS

1	Guidance and manufacturer's declaration - electromagnetic emission		
2	The Grid Pad 13 is intended for use in the electromagnetic environment specified below. The customer or the user of the Grid Pad 13 should assure that it is used in such an environment.		
3	<b>Emissions test</b>	<b>Compliance</b>	<b>Electromagnetic environment - guidance</b>
4	RF emissions CISPR 11	Group 1	The Grid Pad 13 uses RF energy only for its internal function. Therefore, its RF emissions are very low and are not likely to cause any interference in nearby electronic equipment.
5	RF emissions CISPR 11	Class B	The Grid Pad 13 is suitable for use in all establishments, including domestic establishments and those directly connected to the public low-voltage power supply network that supplies buildings used for domestic purposes.
6	Harmonic emissions IEC 61000-3-2	Class A	
7	Voltage fluctuations / flicker emissions  IEC 61000-3-3	Applicable	

## Guidance and manufacturer's declaration - electromagnetic immunity - for all EQUIPMENT and SYSTEMS

Guidance and manufacturer's declaration - electromagnetic immunity			
The Model Grid Pad 13 are intended for use in the electromagnetic environment specified below. The customer or the user of the Model Grid Pad 13 should assure that it is used in such an environment.			
Immunity test	IEC 60601 test level	Compliance level	Electromagnetic environment - guidance
Electrostatic discharge (ESD)  IEC 61000-4-2	± 8 kV contact  ± 2 kV, ± 4 kV, ± 8 kV, ± 15 kV air	± 8 kV contact  ± 2 kV, ± 4 kV, ± 8 kV, ± 15	Floors should be wood, concrete or ceramic tile. If floors are covered with synthetic material, the relative humidity should be at least 30 %.
Electrostatic transient / burst  IEC 61000-4-4	± 2 kV for power supply lines 100 kHz repetition frequency ± 1 kV for input/output lines	± 2 kV for power supply lines 100 kHz repetition frequency	Mains power quality should be that of a typical commercial or hospital environment.
Surge  IEC 61000-4-5	± 0.5 kV, ± 1 kV differential mode line-line	± 0.5 kV, ± 1 kV differential mode line-line	Mains power quality should be that of a typical commercial or hospital environment.
Voltage dips, short interruptions and voltage variations on power supply input lines  IEC 61000-4-11	0 % UT (100 % dip in UT) for 0.5 cycle at 0°, 45°, 90°, 135°, 180°, 225°, 270°, and 315°  0 % UT (100 % dip in UT) for 1 cycle at 0°  70 % UT (30 % dip in UT) for 25/30 cycles at 0°  0 % UT (100 % dip in UT) for 250/300 cycle at 0°	0 % UT (100 % dip in UT) for 0.5 cycle at 0°, 45°, 90°, 135°, 180°, 225°, 270°, and 315°  0 % UT (100 % dip in UT) for 1 cycle at 0°  70 % UT (30 % dip in UT) for 25/30 cycles at 0°  0 % UT (100 % dip in UT) for 250/300 cycle at 0°	Mains power quality should be that of a typical commercial or hospital environment. If the user of the Grid Pad 13 requires continued operation during power mains interruptions, it is recommended that the Grid Pad 13 be powered from an uninterruptible power supply or a battery.

Power frequency (50/60 Hz) magnetic field IEC 61000-4-8	30 A/m, 50/60Hz	30 A/m, 50/60Hz	Power frequency magnetic fields should be at levels characteristic of a typical location in a typical commercial or hospital environment.
--	-----------------	-----------------	---

NOTE: UT is the a. c. mains voltage prior to application of the test level.

### Guidance and MANUFACTURER'S declaration - electromagnetic IMMUNITY

#### Guidance and manufacturer's declaration - electromagnetic immunity

The Grid Pad 13 is intended for use in the electromagnetic environment specified below. The customer or the user of the Grid Pad 13 should assure that it is used in such an environment.

Immunity test	EC 60601 test level	Compliance level	Electromagnetic environment - guidance
Conducted RF IEC 61000-4-6 Radiated RF IEC 61000-4-3	3 Vrms 150 kHz to 80 MHz 6 Vrms 150 kHz to 80 MHz outside ISM bandsa 10 V/m 80 MHz to 2.7 GHz	3 Vrms 150 kHz to 80 MHz 6 Vrms 150 kHz to 80 MHz outside ISM bandsa 10 V/m	Portable and mobile RF communications equipment should be used no closer to any part of the Grid Pad 13, including cables, than the recommended separation distance calculated from the equation applicable to the frequency of the transmitter.  Recommended separation distance  $d = \left[ \frac{3.5}{V_1} \right] \sqrt{P}$  $d = \left[ \frac{3.5}{E_1} \right] \sqrt{P}$ 80MHz to 800MHz  $d = \left[ \frac{7}{E_1} \right] \sqrt{P}$ 800MHz to 2.7GHz where P is the maximum output power rating of the transmitter in watts (W) according to the transmitter manufacturer and d is the recommended separation distance in metres(m).  Field strengths from fixed RF transmitters, as determined by an electromagnetic site survey, a should be less than the compliance level in each frequency range b Interference may occur in the vicinity of equipment marked with the following symbol:  

NOTE 1 At 80 MHz and 800 MHz, the higher frequency range applies.

NOTE 2 These guidelines may not apply in all situations. Electromagnetic propagation is affected by absorption and reflection from structures, objects and people.

a The ISM (industrial, scientific and medical) bands between 0,15 MHz and 80 MHz are 6,765 MHz to 6,795 MHz; 13,553 MHz to 13,567 MHz; 26,957 MHz to 27,283 MHz; and 40,66 MHz to 40,70 MHz.

The amateur radio bands between 0,15 MHz and 80 MHz are 1,8 MHz to 2,0 MHz, 3,5 MHz to 4,0 MHz, 5,3 MHz to 5,4 MHz, 7 MHz to 7,3 MHz, 10,1 MHz to 10,15 MHz, 14 MHz to 14,2 MHz, 18,07 MHz to 18,17 MHz, 21,0 MHz to 21,4 MHz, 24,89 MHz to 24,99 MHz, 28,0 MHz to 29,7 MHz and 50,0 MHz to 54,0 MHz.

b The compliance levels in the ISM frequency bands between 150 kHz and 80 MHz and in the frequency range 80 MHz to 2,7 GHz are intended to decrease the likelihood that mobile/portable communications equipment could cause interference if it is inadvertently brought into patient areas. For this reason, an additional factor of 10/3 has been incorporated into the formulae used in calculating the recommended separation distance for transmitters in these frequency ranges.

c Field strengths from fixed transmitters, such as base stations for radio (cellular/cordless) telephones and land mobile radios, amateur radio, AM and FM radio broadcast and TV broadcast cannot be predicted theoretically with accuracy. To assess the electromagnetic environment due to fixed RF transmitters, an electromagnetic site survey should be considered. If the measured field strength in the location in which the Grid Pad 10s is used exceeds the applicable RF compliance level above, the Grid Pad 10s should be observed to verify normal operation. If abnormal performance is observed, additional measures may be necessary, such as re-orienting or relocating the Grid Pad 13.

d Over the frequency range 150 kHz to 80 MHz, field strengths should be less than 10 V/m.

### Recommended separation distances between portable and mobile RF communications equipment and the EQUIPMENT or SYSTEM

Recommended separation distances between portable and mobile RF communications equipment and the model Grid Pad 13			
The Grid Pad 13 is intended for use in an electromagnetic environment in which radiated RF disturbances are controlled. The customer or the user of the Grid Pad 13 can help prevent electromagnetic interference by maintaining a minimum distance between portable and mobile RF communications equipment (transmitters) and the Grid Pad 13 as recommended below, according to the maximum output power of the communications equipment.			
Rated maximum output of transmitter  W	Separation distance according to frequency of transmitter m		
	150 kHz to 80 MHz	80 MHz to 800 MHz	800 MHz to 2.7 GHz
	$d = \left[ \frac{3.5}{V_1} \right] \sqrt{P}$	$d = \left[ \frac{3.5}{E_1} \right] \sqrt{P}$	$d = \left[ \frac{7}{E_1} \right] \sqrt{P}$
0.01	0.12	0.04	0.07
0.1	0.37	0.12	0.23
1	1.17	0.35	0.7
10	3.7	1.11	2.22
100	11.7	3.5	7.0
For transmitters rated at a maximum output power not listed above the recommended separation distance d in metres (m) can be estimated using the equation applicable to the frequency of the transmitter, where P is the maximum output power rating of the transmitter in watts (W) according to the transmitter manufacturer.			
NOTE 1 At 80 MHz and 800 MHz, the separation distance for the higher frequency range applies.			
NOTE 2 These guidelines may not apply in all situations. Electromagnetic propagation is affected by absorption and reflection from structures, objects and people.			

**Recommended separation distances between RF wireless communications equipment**

The device is intended for use in an electromagnetic environment in which radiated RF disturbances are controlled. The customer or the user of the device can help prevent electromagnetic interference by maintaining a minimum distance between RF wireless communications equipment and the device as recommended below, according to the maximum output power of the communications equipment.

Frequency MHz	Maximum Power W	Distance	IEC 60601 Test Level	Compliance Level	Electromagnetic Environment - Guidance
385	1.8	0.3	27	27	RF wireless communications equipment should be used no closer to any part of the device, including cables, than the recommended separation distance calculated from the equation applicable to the frequency of the transmitter.  <b>Recommended separation distance</b>  $E = \frac{6}{d} \sqrt{P}$ Where P is the maximum output power rating of the transmitter in watts (W) according to the transmitter manufacturer and d is the recommended separation distance in meters (m). Field strengths from fixed RF transmitter, as determined by an electromagnetic site survey, should be less than the compliance level in each frequency range. Interference may occur in the vicinity of equipment marked with the following symbol:  
450	2	0.3	28	28	
710	0.2	0.3	9	9	
745					
780					
810	2	0.3	28	28	
870					
930					
1720					
1845	2	0.3	28	28	
1970					
2450					
5240	0.2	0.3	9	9	
5500					
5785					

Note 1: These guidelines may not apply in all situations. Electromagnetic propagation is affected by absorption and reflection from structures, objects and people.

**WARNINGS**

- This device should not be used in the vicinity or on the top of other electronic equipment such as cell phone, transceiver or radio control products. If you have to do so, the device should be observed to verify normal operation.
- The use of accessories and power cord other than those specified, with the exception of cables sold by the manufacturer of the equipment or system as replacement parts for internal components, may result in increased emissions or decreased immunity of the equipment or system.



# Grid Pad 13

**Smartbox**  
Communication is life

Grid Pad 13 - Manual & Safety - UK ENG - B